

CONCEPT MONITORS
OPERATING INSTRUCTIONS - 1.3

CX



CXP-110

CXP-112

CXP-115

CXm-110

CXm-112

CXm-115

USER MANUAL

Laney

IMPORTANT SAFETY INSTRUCTIONS



WARNING: When using electric products, basic cautions should always be followed, including the following.

1. Read all safety and operating instructions before using this product
2. The product should be powered by a three pin grounded (or earthed) plug connected to a power socket with a grounded earth outlet.
3. All safety and operating instructions should be retained for future reference
4. Obey all cautions in the Operating instructions and on the back of the unit
5. All operating instructions should be followed
6. This product should not be used near water, i.e. a bathtub, sink, swimming pool, wet basement, etc.
7. This product should be located so that its position does not interfere with its proper ventilation. It should not be placed flat against a wall or placed in a built up enclosure that will impede the flow of cooling air.
8. This product should not be placed near a source of heat such as stove, radiator, or another heat producing amplifier.
9. Connect only to a power supply of the type marked on the unit adjacent to the power supply cord.
10. Never break off the ground pin on a power supply cord.
11. Power supply cords should always be handled carefully. Never walk or place equipment on power supply cords. Periodically check cords for cuts or signs of stress, especially at the plug and the point where the chord exits the unit.
12. The power supply cord should be unplugged when the unit is to be unused for long periods of time.
13. If this product is to be mounted in an equipment rack, rear support should be provided.
14. The user should allow easy access to any mains plug, mains coupler and mains switch used in conjunction with this unit thus making it readily operable.
15. Metal parts can be cleaned with a damp cloth. The vinyl covering used on some units can be cleaned with a damp cloth or ammonia based household cleaner if necessary. Disconnect the unit from the power supply before cleaning.
16. Care should be taken so that objects do not fall and liquids are not spilled into the unit through any ventilation holes or openings. On no account place drinks on the unit.
17. A qualified service technician should check the unit if:
 - The power cord has been damaged
 - Anything has fallen or spilled into the unit
 - The unit does not appear to operate correctly
 - The unit has been dropped or the enclosure damaged.
18. The user should not attempt to service the equipment. All service work is done by a qualified service technician.
19. Exposure to extremely high noise levels may cause a permanent hearing loss. Individuals vary considerably in susceptibility to noise induced hearing loss, but nearly everyone will lose some hearing if exposed to sufficiently intense noise for a sufficient time. The U.S. Government's Occupational Safety and Health Administration (OSHA) has specified the following permissible noise level exposure. (See opposite).

Duration Per Day In Hours	Sound Level dBA, slow response
8	90
6	92
4	95
3	97
2	100
1 ½	102
1	105
½	110
¼ or less	115

According to OSHA, any exposure in excess of the permissible limits could result in some hearing loss. Ear plugs or protectors in the ear canals or over the ears must be worn when operating this amplification system in order to prevent a permanent hearing loss if exposure exceeds the limits set forth above. To ensure against potentially dangerous exposure to high sound pressure levels it is recommended that all persons exposed to equipment capable of producing high sound pressure levels such as this amplification system be protected by hearing protectors while this unit is in operation.

SAVE THESE INSTRUCTIONS

	<p>Intended to alert the user to the presence of uninsulated 'Dangerous Voltage' within the products enclosure that may be sufficient to constitute a risk of electrical shock to persons.</p> <p>Ce symbole est utilisé pur indiquer a l'utilisateur de ce produit de tension non-isolee dangereuse pouvant etre d'intensite suffisante pour constituer un risque de choc electrique.</p> <p>Este simbolo tiene el proposito de alertar al usuario de la presencia de '(voltaje) peligroso' que no tiene aislamiento dentro de la caja del producto que puede tener una magnitud suficiente como para constituir riesgo de corrientazo.</p> <p>Dieses Symbol soll den Anwender vor unisolierten gefahrlichen Spannungen innerhalb des Gehauses warnen, die von Ausreichender Starke sind, um einen elektrischen Schlag verursachen zu konnen.</p>
	<p>Intended to alert the user of the presence of important operating and maintenance (Servicing) instructions in the literature accompanying the product.</p> <p>Dieses Symbol soll den Anwender vor unisolierten gefahrlichen Spannungen innerhalb des Gehauses warnen, die von Ausreichender Starke sind, um einen elektrischen Schlag verursachen zu konnen.</p> <p>Este simbolo tiene el proposito de la alertar al usuario de la presencia de instrucccones importantes sobre la operacion y mantenimiento en la literatura que viene conel producto.</p> <p>Dieses Symbol soll den Benutzer auf wichtige Instruktionen in der Bedienungsanleitung aufmerksam machen, die Handhabung und Wartung des Produkts betreffen.</p>
<p>CAUTION:</p> <p>ATTENTION:</p> <p>PRECAUCION:</p> <p>VORSICHT:</p>	<p>Risk of electrical shock - DO NOT OPEN. To reduce the risk of electrical shock, do not remove the cover. No user serviceable parts inside. Refer servicing to qualified personnel.</p> <p>Risques de choc electrique - NE PAS OUVIRIR Afin de reduire le risque de choc electrique, ne pas enlever le couvercle. Il ne se trouve a l'interieur aucune piece pouvant etre reparee par l'utilisateur. Confier l'entretien a un personnel qualifie.</p> <p>Riesgo de corrientazo - no abra Para disminuir el risego de corrientazo, no abra la cubierta. No hay piezas adentro que el pueda reparar. Deje todo mantenimiento a los tecnicos calificadod.</p> <p>Risiko - Elektrischer Schlag! Nicht offen! Um das Risiko eines elektrischen Schlages zu vermeiden, nicht die Abdeckung entfernen. Es befinden sich keine Teile darin, die vom Anwender repariert werden Konnten. Reparaturen nur von qualifiziertem Fachpersonal durchfuhren lassen.</p>
<p>WARNING:</p> <p>ADVERTISSEMENT:</p> <p>ADVERTENCIA:</p> <p>ACHTUNG:</p>	<p>To prevent electrical shock or fire hazard, do not expose this appliance to rain or moisture. Before using this appliance please read the operating instructions for further warnings.</p> <p>Afin de prevenir les risques de decharge electrique ou de feu, n'exposez pas cet appareil a la pluie ou a l'humidite. Avant d'utiliser cet appareil, lisez les advertissments supplentaires situes dans le guide.</p> <p>Para evitar corrientazos o peligro de incendio, no deja expuesto a la lluvia o humedad este aparato Antes de usar este aparato, lea mas advertcias en la guia de operacion.</p> <p>Um einen elektrischen Schalg oder Feuergefahr zu vermeiden, sollte dieses Gerat nicht dem Regen oder Feuchtigkeit ausgesetzt werden. Vor Inbetriebnahme unbedingt die Bedienungsanleitung lesen.</p>

BEFORE SWITCHING ON

After unpacking your amplifier check that it is factory fitted with a three pin 'grounded' (or earthed) plug. Before plugging into the power supply ensure you are connecting to a grounded earth outlet.

If you should wish to change the factory fitted plug yourself, ensure that the wiring convention applicable to the country where the amplifier is to be used is strictly conformed to. As an example in the United Kingdom the cable colour code for connections are as follows.

EARTH or GROUND GREEN/YELLOW
NEUTRAL - BLUE
LIVE - BROWN



NOTE

This manual has been written for easy access of information. The front and rear panels are graphically illustrated, with each control and feature numbered. For a description of the function of each control feature, simply check the number with the explanations adjacent to each panel.

Your Laney amplifier has undergone a thorough two stage, pre-delivery inspection, involving actual play testing. When you first receive your Laney guitar amplifier, follow these simple procedures:

- (i) Ensure that the amplifier is the correct voltage for the country it is to be used in.
- ii) Connect your instrument with a high quality shielded instrument cable. You have probably spent considerable money on your amplifier and guitar - don't use poor quality cable it won't do your gear justice.

Please retain your original carton and packaging so in the unlikely event that some time in the future your amplifier should require servicing you will be able to return it to your dealer securely packed.

Care of your Laney amplifier will prolong it's life.....and yours!

Laney

Dear Player,

Thank you very much for purchasing your new Laney product and becoming part of the worldwide Laney family. Each and every Laney unit is designed and built with the utmost attention to care and detail, so I trust yours will give you many years of enjoyment.

Laney products have a heritage which stretches back to 1967 when I first began building valve amplifiers in my parent's garage. Since then we have moved on from strength to strength developing an extensive range of guitar, bass, public address and keyboard amplification products along with a list of Laney endorsees that includes some of the world's most famous and respected musicians. At the same time we believe we have not lost sight of the reason Laney was founded in the first place - a dedication to building great sounding amplification for working musicians.

Warm Regards,



Lyndon Laney CEO

INTRODUCTION

CX monitors are compact, functional and most importantly loud - this range of powered and unpowered monitors offers an effective solution to your onstage monitoring needs.

Designed to give a compact, affordable solution to onstage monitoring, the Concept CX Range of powered (CXP models) and unpowered (CXM models) offer outputs from 125W to 250W RMS in 10", 12" and 15" speaker options. CXP models feature both Mic and Line In inputs, with 2 band EQ on the CXP-110 and 3 band EQ on the CXP-112 and CXP-115 for maximum sound quality.

Cabinet design: full range ported stage monitor, road ready construction with kick-proof metal grille, carry handle, metal corners & rubber feet

We hope you enjoy using your CX Monitor as much as we enjoyed designing and making it.

Best wishes from all at Laney.

CXP POWERED MONITOR RANGE

Laney



CXP-110



CXP-112



CXP-115



CONCEPT MONITORS

CX
5

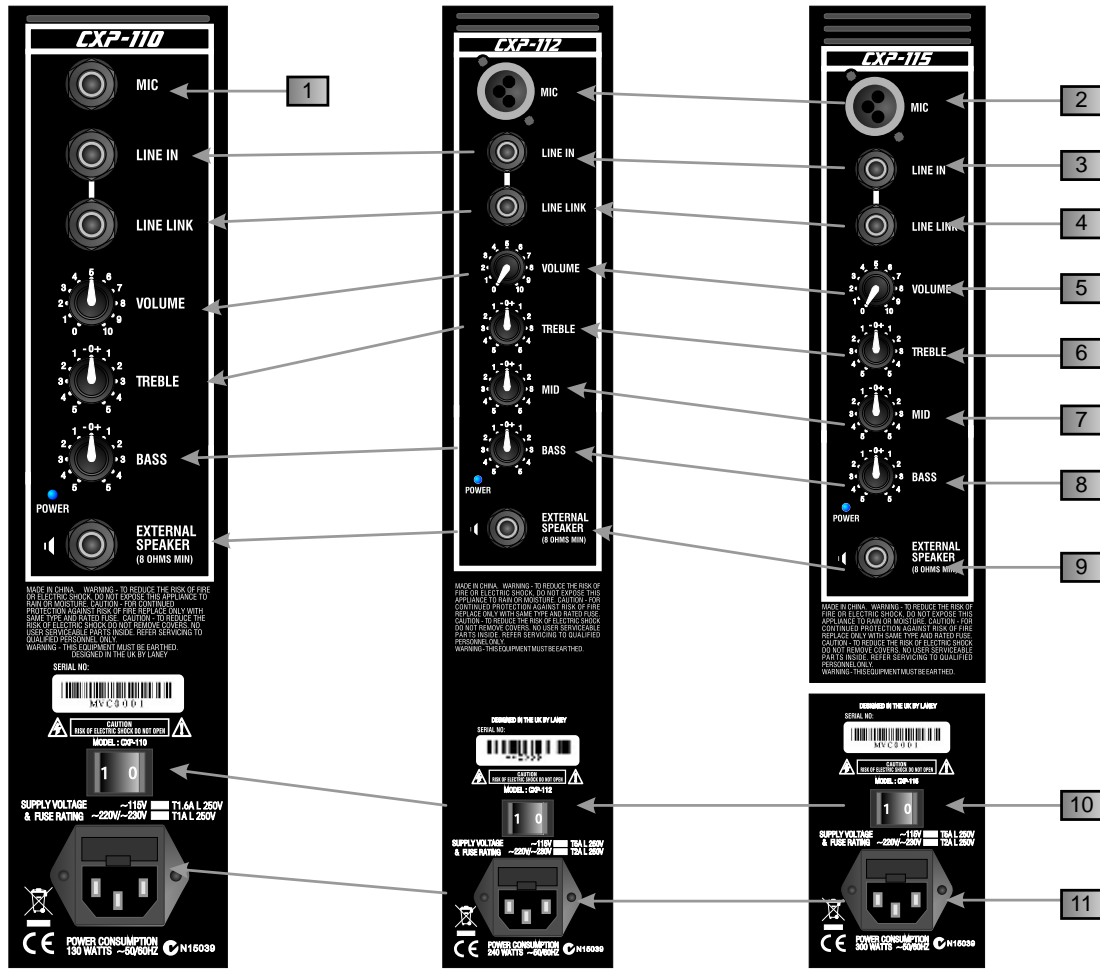

- 1 Mic: Jack input for Lo impedance microphones (200-600 Ohms)
- 2 Mic: XLR input for Lo impedance microphones (200-600 Ohms)
- 3 Line In: Jack input socket for all line level signals e.g.: Keyboard, P.A., Mixing Desk Drum Machine etc.
- 4 Link Out: Socket for providing a link out for any device connected to "Line In" only.
- 5 Volume: Controls the overall listening level of the monitor.
- 6 Treble: Controls the HI frequency response of the monitor.
- 7 Mid: Controls the MID frequency response of the monitor.
- 8 Bass: Controls the LOW frequency response of the monitor.
- 9 Loudspeakers: Output socket for connecting a further unpowered monitor such as CXM-110, CXM-112 or CXM-115, The impedance of the speakers should not be less than 8 Ohms. Connecting cabinets that have a lower impedance than 8 Ohms could result in the amplifier being permanently damaged.
- 10 Main Power Switch: Main power switch for the unit. Power LED, when illuminated indicates that power is connected to the unit and it is ready to go. (Always switch off and disconnect the power cord when not in use)
- 11 Power Inlet Socket: Connect your power source here. Make sure that the specified voltage is correct for your country! Also here in the drawer is the main safety fuse for the unit. Only use the correct size and rating of fuse as specified on the panel.

Laney

TECHNICAL SPECIFICATIONS & BLOCK DIAGRAM

<i>CXP-110</i>	<i>CXP-112</i>	<i>CXP-115</i>
-----------------------	-----------------------	-----------------------

Supply voltage on all models: - Factory Preset ~100V, ~120V, ~220V, ~230V, ~240V 50/60Hz

Mains Fuse:	~100V~120V ~220V~240V	T1.6A L T1A L	T5A L T2A L	T5A L T2A L
Inputs	Mic. Line (both 6.3mm Jacks)	Mic XLR, 6.3mm Line jack	Mic XLR, 6.3mm Line jack	Mic XLR, 6.3mm Line jack
EQ	2 band Active Shelving	3 band Active Shelving	3 band Active Shelving	3 band Active Shelving
Line In input impedance	10Kohms	10Kohms	10Kohms	10Kohms
Link Out	Directly coupled to Line In	Directly coupled to Line In	Directly coupled to Line In	Directly coupled to Line In
Mic input impedance	2Kohms Balanced	2Kohms Balanced	2Kohms Balanced	2Kohms Balanced
Nominal Line input level	-10dBu	-10dBu	-10dBu	-10dBu
Nominal Mic input level	-20dBu	-20dBu	-20dBu	-20dBu
Extension Loudspeaker	8 ohms minimum	8 ohms minimum	8 ohms minimum	8 ohms minimum
Speaker Nom Impedance	8 ohms	8 ohms	8 ohms	8 ohms
Speaker Size	10" + Piezo Tweeter	12" + HF Horn	15" + HF Horn	15" + HF Horn
Output Power	65W RMS, 120W PMPO into 4ohms	120W RMS, 240W PMPO into 4ohms	150W RMS, 300W PMPO into 4ohms	150W RMS, 300W PMPO into 4ohms
Frequency Response	78hz to 20khz	65hz to 18khz	60hz to 18khz	60hz to 18khz
Sensitivity	97 dB/W @1M	98 dB/W @1M	97 dB/W @1M	97 dB/W @1M
Weight	14 Kg	19 Kg	24.5 Kg	24.5 Kg
Size (H*W*D)	274*468*347	330*591*437	343*667*462	343*667*462

This product conforms to the requirements of the following European Regulations, Directives & Rules:-
 CE Mark (93/68/EEC), Low Voltage (72/23/EEC), EMC (93/68/EEC),
 RoHS (EU2002/95/EC), WEEE (EU2002/96/EC)



In order to reduce environmental damage, at the end of its useful life, this product must not be disposed of along with normal household waste to landfill sites. It must be taken to an approved recycling centre according to the recommendations of the WEEE (Waste Electrical and Electronic Equipment) directive applicable in your country.

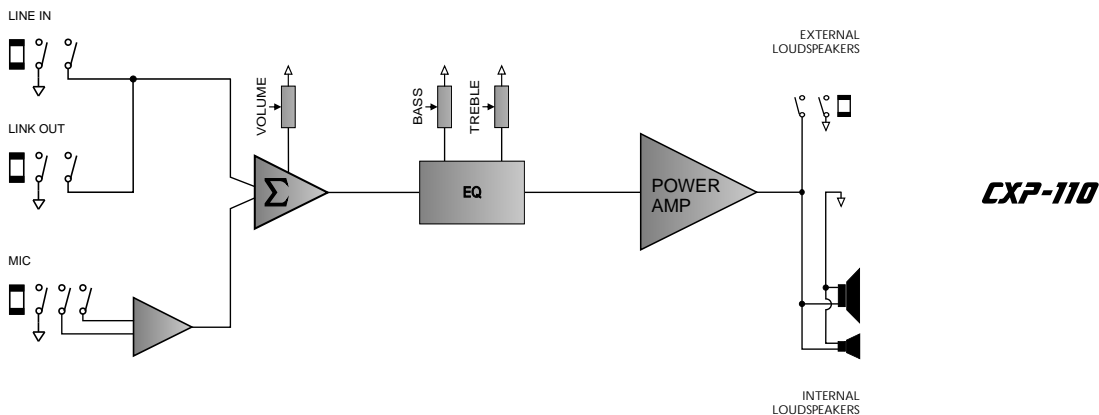

CXP-112

CXP-115

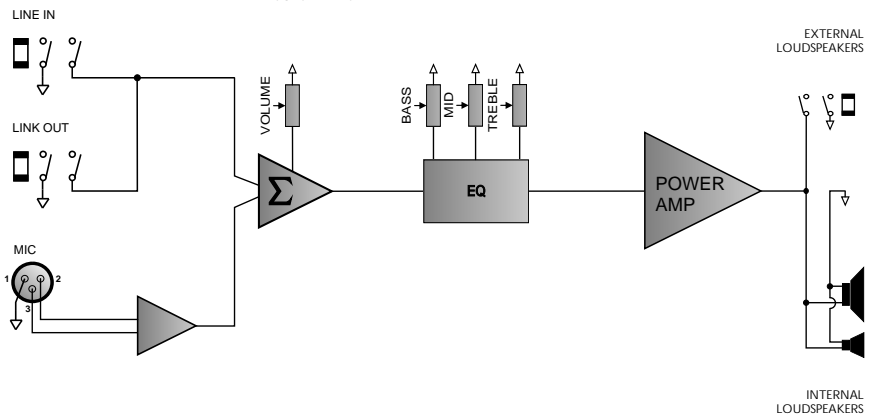

Servicing: The user should not attempt to service these products. Refer all servicing to qualified service personnel.

Cables: Never use shielded or microphone cable for any speaker connections as this will not be substantial enough to handle the amplifier load and could cause damage to your amplifier system.

Laney

CXM UNPOWERED MONITOR RANGE

The CXM range of unpowered monitors are designed to compliment the CXP powered monitors, each of which is capable of powering one unpowered monitor from its external speaker socket.

Each CXM monitor is supplied with two jack sockets on the rear panel, either can be used as an input or link out.

Other power amplifiers can be connected and depending on the specification of the power amplifier, it may be possible to link together a number of unpowered monitors to achieve the desired monitor spread.

Speaker Nom Impedance:	8 Ohms
Speaker Size:	10" + Piezo Tweeter
Speaker Rating:	125W RMS - 500W Peak
Frequency Reponse:	78hz to 20khz
Sensitivity:	97 dB/W@1M
Weight:	11.5Kg
Size (H*W*D):	274*468*347
Speaker Nom Impedance:	8 Ohms
Speaker Size:	12" + Piezo Tweeter
Speaker Rating:	180W RMS - 720W Peak
Frequency Reponse:	65hz to 18khz
Sensitivity:	98 dB/W@1M
Weight:	16Kg
Size (H*W*D):	330*591*437
Speaker Nom Impedance:	8 Ohms
Speaker Size:	15" + Piezo Tweeter
Speaker Rating:	250W RMS - 1000 Peak
Frequency Reponse:	60hz to 18khz
Sensitivity:	97 dB/W@1M
Weight:	21.5Kg
Size (H*W*D):	343*667*462



Laney

CONCEPT MONITORS

CXm-110



CXm-112



CXm-115

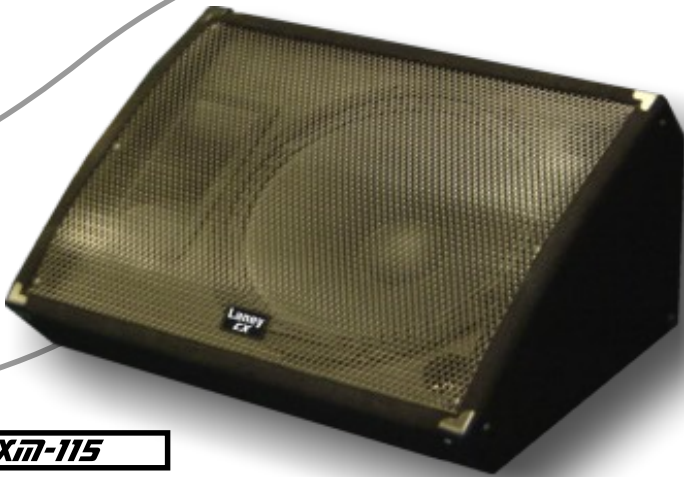

**Laney
CX**

CX
11

Laney
POWER TO THE MUSIC.

LANEY AMPLIFICATION
www.laney.co.uk

In the interest of continued product development, Laney reserves the right to amend product specification without prior notification.